

Flow birefringence in lyotropic mixtures in the isotropic phase

P.R.G. Fernandes and A.M. Figueiredo Neto

Instituto de Física, Universidade de São Paulo, Caixa Postal 20516, 01498-970 - São Paulo, São Paulo, Brazil

(Received 8 June 1993; revised manuscript received 16 June 1994)

The flow-induced birefringence (δn) in lyotropic mixtures in the isotropic phase (ISO) was measured by means of optical techniques. As a function of temperature, the ISO is surrounded by two lamellar (LAM) phases. The shear flow produced by a perturbation in ISO induces a birefringent phase, which relaxes back to ISO with a typical relaxation time τ . τ increases near the transition to the more ordered LAM phases, and the behavior of τ versus temperature indicates the existence of a virtual nematic phase in the isotropic domain.

PACS number(s): 61.30.-v, 64.70.Md, 47.20.Ft

I. INTRODUCTION

Complex and supermolecular fluids [1] present remarkable dynamical properties. In particular, liquid crystals [2] have complex flow regimes because the translational motions are coupled to the orientational motions of the molecules or micelles.

Many experimentalists investigate the flow characteristics of these mesophases essentially by means of optical techniques [2-5].

More recently, considerable effort has been put in the experimental study of micellar complex fluids under shear flow: the shear-induced phase transitions of living polymers [6], the growth dynamic polymers in shear flow [7], and the shear-induced critical dynamics in the tetraethylene glycol *n*-decylether micellar solution [8]. Koppi and co-workers [9] observed that shear increases the isotropic-to-lamellar transition temperature in a symmetric diblock copolymer melt by means of rheological and small-angle neutron scattering measurements.

From the theoretical point of view, de Gennes gave outstanding contributions [2,10] to the understanding of the physics of these dynamical processes. One of his predictions [2] is the divergence of the flow-induced birefringence δn as the phase transition temperature (T_c) approaches and the dependence of δn with the molecular velocity gradient ($\frac{\partial v}{\partial z}$):

$$\delta n = \frac{A}{(T - T^*)} \left| \frac{\partial v}{\partial z} \right|,$$

where T is the temperature, T^* is the second-order transition temperature [3] and A is a constant. Martinoty and co-workers [11] verified this divergence in the 4,4'-di(methoxy)-azobenzene (PAA) thermotropic liquid crystal at the isotropic phase, near the nematic transition.

Peuvrel and Navard [12] report puzzling structures with eyelashes and chevron wakes of birefringence in a liquid crystalline polymer solution in the isotropic phase, induced by flow.

Differently from the thermotropic and polymeric liquid crystals, not many dynamical studies were performed with lyotropic liquid crystals [13] made by amphiphilic molecules and water. These systems, however, are very interesting since they present rich phase diagrams [13,14] as a function of temperature and the relative concentrations of each compound of the mixture. Magnetic field [15] and thermal [16] induced hydrodynamic instabilities in lyotropic uniaxial nematics have already been reported.

The nematic regions of the lyotropic liquid crystals phase diagram are usually surrounded [13] by isotropic domains. In some of these mixtures, in the isotropic phase, when the experimentalist handles a tube with this material inside, placed between crossed polarizers, after shaking it, a strong flow induced birefringence can be observed.

In this paper we present an experimental study of the flow-induced birefringence in the lyotropic mixture of potassium laurate, decanol, and water in the isotropic phase as a function of temperature.

II. EXPERIMENT

The lyotropic liquid crystals used in this work are mixtures [17] of potassium laurate (KL), decanol (DeOH) and water. The concentrations of each compound in weight % are 26.63 wt%, 6.36 wt%, and 67.01 wt%, respectively.

The phase sequence as a function of the temperature (T), determined by optical and x-ray scattering techniques are: LAM (8.5°C) ISO (47.9°C) LAM where ISO and LAM stand for the isotropic and lamellar phases, respectively.

The setup used to measure the transmittance of the sample as a function of time is sketched in Fig. 1.

The lyotropic mixture is encapsulated in a rectangular Hellma glass cell of square section (1 cm \times 1 cm and 2 cm high). A stainless steel square plate of 0.8 cm \times 0.8 cm and 0.1 cm thick is placed inside the cell as shown in Fig. 1(b). A magnetic field of about 200 G keeps

the plate at rest, in the xy plane (at $z = 0$). When the field is switched off, the plate falls, keeping its big surface in the xy plane ($z = 0$). The movement of the plate along the x axis ($\delta x \sim 0.2$ mm); the typical time for the falling of the plate is 0.17 s) promotes a shear in the liquid crystals in contact with it. The cell is placed in a temperature controlled device ($\pm 0.5^\circ\text{C}$ stability), between crossed polarizers. The z axis of the laboratory frame is perpendicular to the square section of the plate, the y axis is the laser light propagation direction, and the x axis is the direction of the movement of the plate inside the cell. A laser beam (HeNe, $\lambda = 6328 \text{ \AA}$) with a circular cross section of about 0.2-cm diameter is directed along the y axis, tangentially to the square surface of the plate as a function of time. The photodiode is coupled to a PC. The time interval between two measured intensities is 1.27×10^{-3} s and the relaxation time of the photodiode is smaller than 1 ms. The computer software and the PC card allow us to accumulate about 2000 measurements in about 2.5 s.

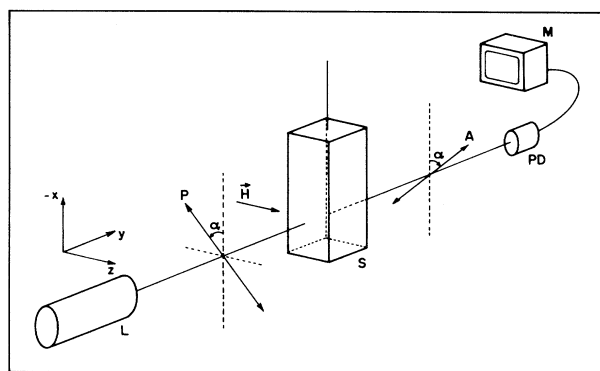

(a)

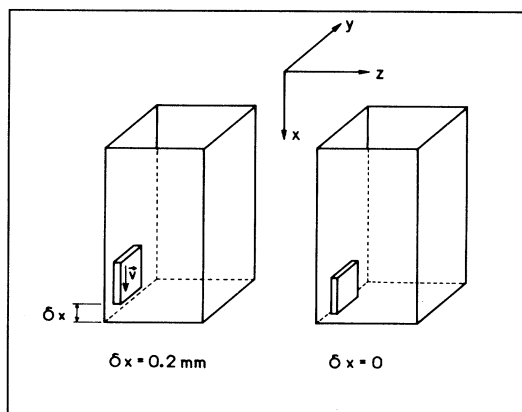

(b)

FIG. 1. (a) Sketch of the setup used to measure the sample transmittance as a function of the time. L is the light source; P and A are the polarizer and the analyzer, respectively; $\alpha = 45^\circ$; S is the sample holder; PD is the photodiode and M is the computer. (b) Detail of the iron plate movement inside the sample holder.

III. RESULTS AND DISCUSSIONS

The methodology of the experiment is the following: first, $H (= 200 \text{ G})$ is applied and the plate inside the sample holder with the lyotropic mixture in the isotropic phase is at its rest position; after that, H is switched off and the plate falls to the bottom of the cell, always keeping its square surface parallel to the xy plane, the total displacement along the x axis is $\delta x \sim 0.2$ mm and the typical falling time is 0.17 s. The photodiode coupled to a PC measures the sample transmittance during the whole process until the velocity gradients which were generated by the movement of the plate vanish. Figure 2 shows the process of switching off the magnetic field applied on the plate as a function of time. The characteristic magnetic field decreasing time is 0.8×10^{-3} s, about 10 times smaller than the typical relaxation times of the sample transmittance.

Figure 3 shows a typical dependence of the sample transmittance as a function of time after the plate has stopped. The velocity gradients, due to the plate movement induce a flow birefringence. Once the shear flow has vanished, the magnitude of the director relaxes and the sample comes back to the isotropic phase. In order to obtain the characteristic relaxation times (τ), an exponential law $I = A + B \exp[-(t - t_0)/\tau]$ was used to fit the experimental data Fig. 3. The inset of Fig. 3 shows the whole process of the plate movement. At $t = 0.5$ s, H is switched off and at 0.67 s the plate stops. Figure 4 shows the relaxation time τ as a function of temperature in the ISO domain. The viscosity of the sample was measured as a function of T , using an Ostwald viscosimeter. Its value increases as temperature approaches the isotropic-to-lamellar phase transition at $T = 8.5^\circ\text{C}$ and $T = 47.9^\circ\text{C}$. In the middle of the ISO domain ($18^\circ\text{C} < T < 32^\circ\text{C}$), the viscosity presented a linear behavior. A similar result has been found [18] in another lyotropic nematic mixture near a lamellar phase transition. The increase of τ near the upper and lower temperature transitions to the lamellar phases is clearly observed in Fig. 4. This result indicates that the relaxation time of the birefringent phase induced by the flow in the ISO phase increases as T approaches the more ordered LAM

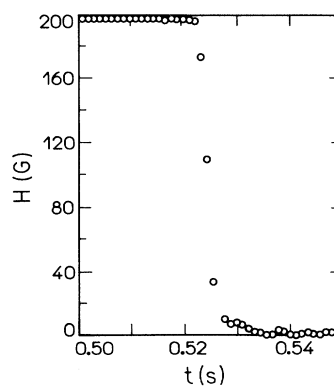

FIG. 2. Process of switching off the magnetic field $H = 200 \text{ G}$ applied on the plate.

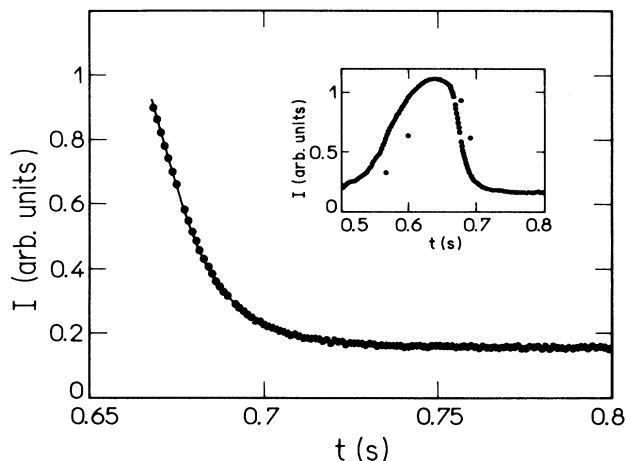

FIG. 3. Transmittance (I) in arbitrary units as a function of the time after the plate stops. $T = 17.2^\circ\text{C}$. The solid line is an exponential fit with $\tau = 12.8$ ms. The inset shows I during the whole process.

phases. The intermicellar correlations are expected to increase near the ISO-to-LAM transition. The relaxation of the flow-induced birefringence (measured by τ) becomes slower as T approaches the ISO-to-LAM transition temperatures. At this point we assume that in a first-order approximation, τ is qualitatively a measurement of the intermicellar correlation. The existence of a maximum in Fig. 4 near 24°C seems to be more intriguing. This increasing of τ near 24°C indicates that the isotropic phase in the temperature range of 8.5°C – 47.9°C could have different correlation properties between micelles. In particular, the maximum in τ versus T in the middle of the isotropic phase could indicate the existence of a “virtual nematic phase” (VNP). A real nematic phase could be produced by a little increase in the amphiphilic concentration in the sample as we experimentally checked. Let us take, for instance, a sample that has about 0.2 wt% plus KL and 1 wt% plus DeOH; it presents a calamitic nematic (N_c) phase at room temperature. On observing the usual topology of the lyotropic nematic phase diagrams [13,17], we have noticed that on increasing the water concentration (keeping wt % of DeOH constant), the nematic domain becomes smaller and it is always surrounded by an isotropic region. For a given concentra-

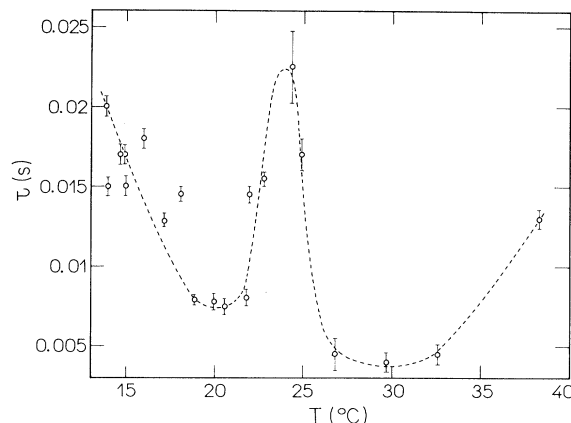

FIG. 4. Adjustable relaxation time τ (see text) as a function of temperature. The dashed line drawn is only a guide to the eyes.

tion, the nematic domain vanishes and only the isotropic domain remains. The sample investigated in this paper is very near this critical limit in water concentration and the analysis of the parameter τ indicates that the mixture tends to present a birefringent phase (probably a nematic phase), not really observed, a VNP.

IV. CONCLUSIONS

The flow produced by a perturbation in an isotropic lyotropic phase was studied. An adjustable parameter τ that informs about the extent of the correlation properties among the micelles was introduced and experimentally obtained. The analysis of the results indicate that τ increases near the isotropic-to-lamellar phase transition. The existence of a maximum in the curve τ versus T near 24°C was interpreted as an indication of a *virtual nematic phase*.

ACKNOWLEDGMENTS

We thank Fundação de Amparo à Pesquisa do Estado de São Paulo and CNPq for financial support. It is also a pleasure to thank Professor Jean Claude Bacri for very helpful discussions.

- [1] E. Dubois-Violette, G. Durand, E. Guyon, P. Manneville and Pieranski, in *Liquid Crystals*, edited by L. Liebert, Solid State Physics Vol. 14 (Academic Press, New York, 1978).
- [2] P.G. de Gennes, *The Physics of Liquid Crystals* (Clarendon, Oxford, 1974).
- [3] S. Chandrasekhar, *Cambridge Monographs on Physics* (Cambridge University Press, London, 1980).
- [4] R.S. Porter, E. M. Barrall II, and J.F. Johnson, *J. Chem. Phys.* **45**, 1452 (1966).
- [5] J. Wahl and F. Fisher, *Opt. Commun.* **5**, 341 (1972).
- [6] S.Q. Wang, *J. Phys. Chem.* **94**, 8382 (1990).
- [7] S.Q. Wang, *Macromol.* **24**, 3004 (1991).
- [8] K. Hamano, S. Yamashita, and J.V. Sengers, *Phys. Rev. Lett.* **68**, 3579 (1992).
- [9] K.A. Koppi, M. Tirrell, and F.S. Bates, *Phys. Rev. Lett.* **70**, 1449 (1993).
- [10] P.G. de Gennes, *Phys. Lett. A* **30**, 454 (1969); *Mol. Cryst. Liq. Cryst.* **12**, 193 (1971).
- [11] P. Martinoty, S. Candau, and F. Debeauvais, *Phys. Rev. Lett.* **27**, 1123 (1971).
- [12] E. Peuvrel and P. Navard, *Liq. Cryst.* **7**, 95 (1990).

- [13] L.J. Yu and A. Saupe, *Phys. Rev. Lett.* **45**, 1000 (1980).
[14] Z.A. de Sant'Ana and A.M. Figueiredo Neto, *Phys. Rev. A* **46**, 7630 (1992).
[15] J. Charvolin and Y. Hendriks, *J. Phys. Lett. (Paris)* **41**, 597 (1980).
[16] A.J. Palangana, J. Depeyrot, and A.M. Figueiredo Neto, *Phys. Rev. Lett.* **65**, 2800 (1990).
[17] A.M. Figueiredo Neto, L. Liebert, and Y. Galerne, *J. Phys. Chem.* **89**, 3737 (1985).
[18] E. Zhou, M. Stefanov, and A. Saupe, *J. Chem. Phys.* **88**, 5137 (1988).